

# INNOVATION OF UV TECHNOLOGY



Guangdong Ruixin Electronics Technology Co.,LTD

Address: 1st-3rd Floor, No.2 Building, Zhiye Road, Zhushan Industrial Park, Dalong town, Panyu District, Guangzhou City, Guang Dong Province, China.

Postal Code: 511450

Tel: 020-39122056

Email: [info@goodiuv.com](mailto:info@goodiuv.com)

Service hotline: 400-188-3266

Web: [www.goodiuv.com](http://www.goodiuv.com)

[www.goodiuv.cn](http://www.goodiuv.cn)

[www.goodiuv.ru](http://www.goodiuv.ru)

[www.goodiuv.es](http://www.goodiuv.es)





Mercury UV/Traditional UV

| Advantage   | Disadvantage  |
|---|---|
| <ol style="list-style-type: none"> <li>1. Ultraviolet band covers a wide range, and ink is easy to produce.</li> <li>2. The power supply is relatively simple, and magnetic flux leakage transformer or digital electronic ballast can be used.</li> <li>3. The technology is mature and the price is low.</li> </ol> | <ol style="list-style-type: none"> <li>1. Low efficiency, high heat and high energy consumption.</li> <li>2. Environmental problems such as mercury in lamp tubes, ozone generation and noise pollution.</li> <li>3. The lamp tube has a short service life and high maintenance cost.</li> <li>4. Boot-up needs preheating, shutdown needs to wait for cooling, which wastes time.</li> <li>5. High standby power.</li> <li>6. The luminous energy of lamp tube is not uniform.</li> </ol> |

LED UV

| Advantage   | Disadvantage  |
|---|---|
| <ol style="list-style-type: none"> <li>1. High luminous efficiency and good wavelength selectivity.</li> <li>2. Compared with mercury ARC lamp, it can save more than 70% electricity.</li> <li>3. The infrared and visible light produced are relatively small, so the temperature is low, and it is suitable for thermal sensitive materials.</li> <li>4. Out of the box, stop immediately, no waiting.</li> <li>5. Long service life, ideal life of up to 50,000 hours.</li> <li>6. Ultraviolet energy density in irradiation area is high and uniformly distributed to ensure printing quality.</li> <li>7. Ozone-free, mercury-free and low noise.</li> <li>8. The cost of use and maintenance are low.</li> </ol> | <ol style="list-style-type: none"> <li>1. Ultraviolet spectrum emitted is single. It needs to cooperate with ink in order to achieve high-efficiency curing effect.</li> <li>2. LED chips are sensitive to temperature and require high heat dissipation, so they need to be equipped with a set of efficient water-cooling equipment.</li> <li>3. The diode characteristics of LED vary greatly with the voltage and current, so the power supply needs to choose a precision adjustable current source for power supply.</li> </ol> |

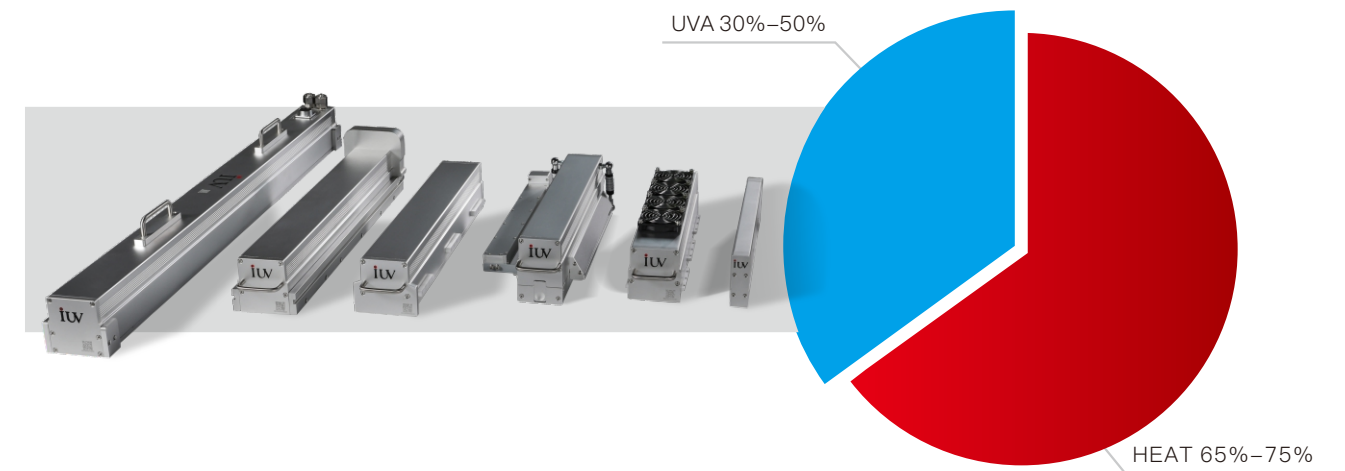
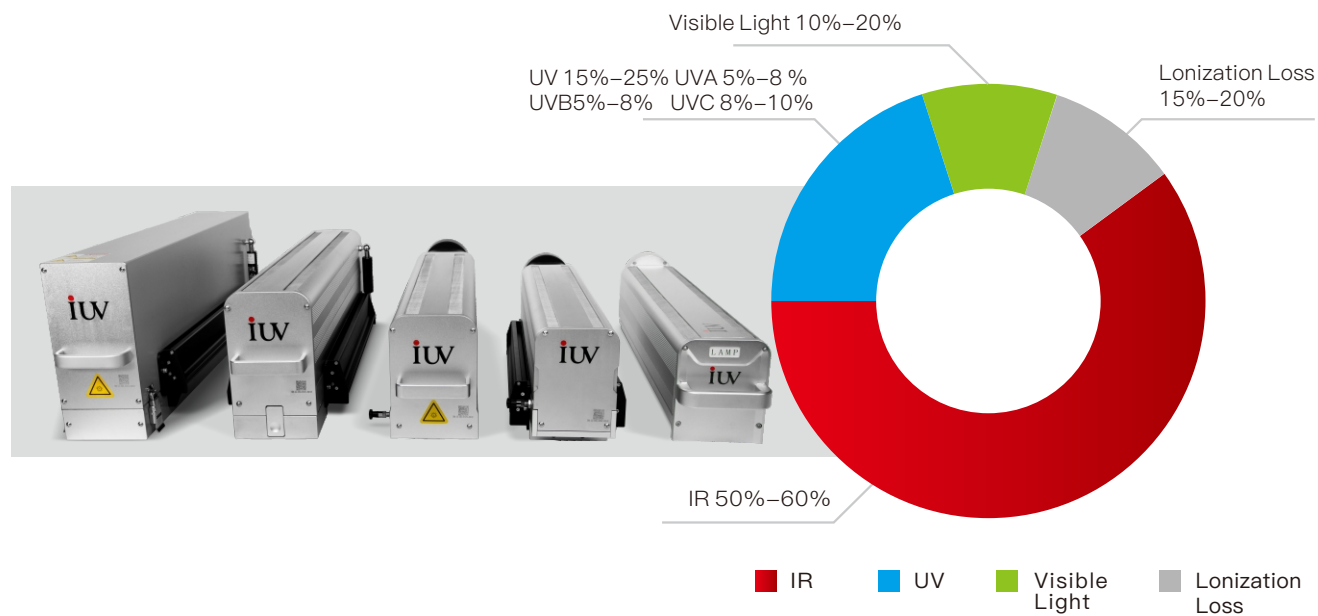

## LED lamp box and mercury lamp box can interchange freely

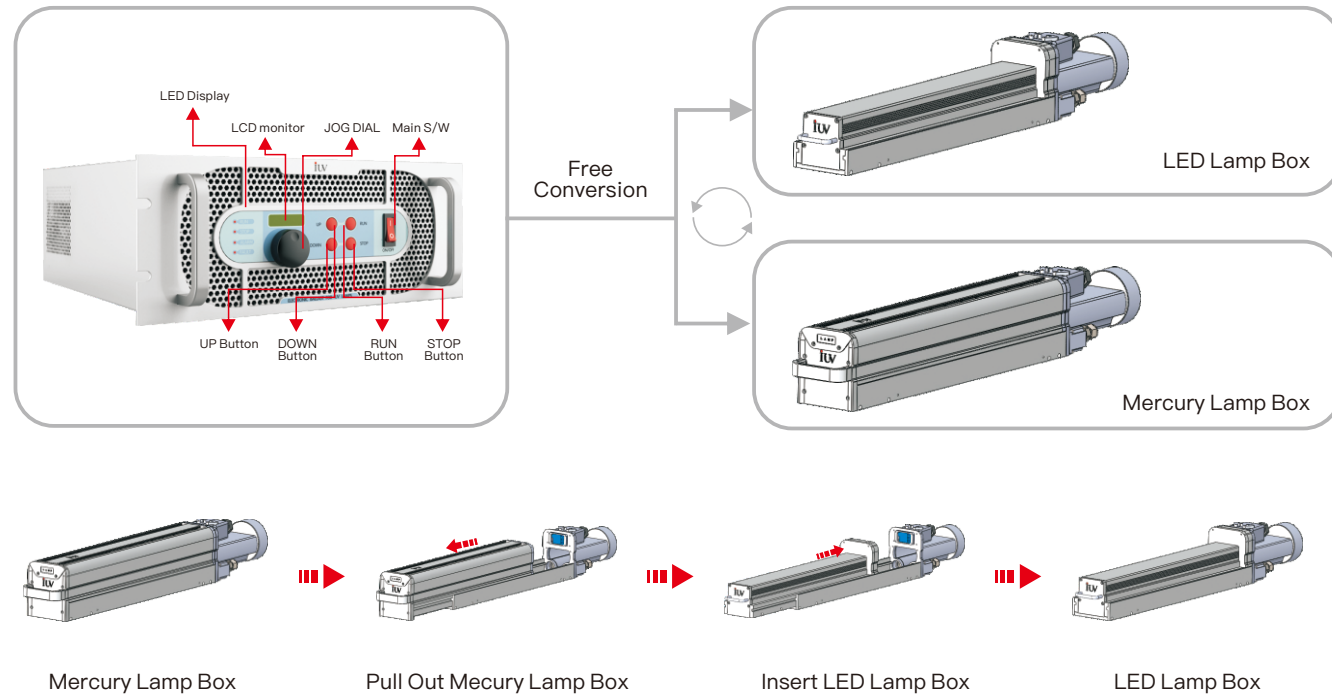

## Benefits of interchangeable UV curing system

1. The variety of printing products which determine the printing ink and a variety of materials. And some materials are not suitable for the curing characteristics of LED.
2. The position of adopting the special ink color group is in a state of constant change.
3. The switching operation of manufacturing technique, it requires the continuous improvement of the production efficiency.
4. With the promotion of energy saving and emission reduction, the manufacturing technique is constantly improving.



## Characteristics and advantages

1. Mercury lamp, halogen lamp and LED Lamp box could be inserted and pulled out freely.
2. The system could be identified automatically without other operation.
3. Keep the water cooling structure of LED Lamp box, high-efficiency and environment protection.
4. Complement each other, adapt to all the requirement of the printing curing process.

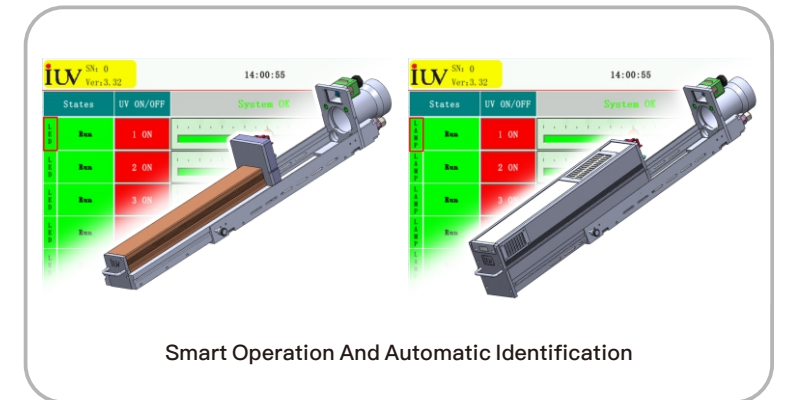

The same power module contains two software algorithms. According to different load, the power supply mode can be automatically switched. It can supply power to mercury lamp or LED light source.

The two lamp boxes can be freely plugged and unplugged, and the system can automatically identify. Without any other human operation, the two lamp boxes can be switched freely to meet the various needs of customers for curing, improve the production efficiency and reduce production costs.

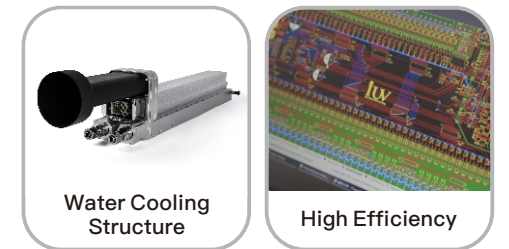
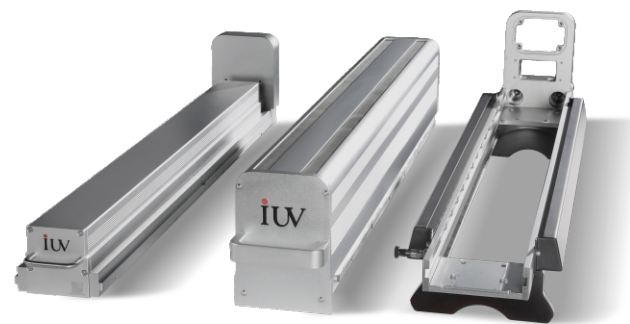

5. Reduce the cost, and improve the production efficiency.

## Advanced power supply device

IUV has developed a unique constant voltage and constant current control system, which can effectively ensure that the working current of each LED chip is the same, extend the working life of the LED as far as possible, and improve the curing quality, curing speed, reliability and expand ability, and ensure the stability and low failure rate of the whole system.

IUV not only provides curing equipment, but also provides a complete set of curing solutions for printing industry.

## Intelligent Functions

- 
1. Man-machine interface, PLC main controller, water cooler, voltage source, current source and LED module light box are all connected by means of communication, which is easy to expand and connect.
  2. Real-time monitoring of parameters and uploading data to higher-level servers for higher-level control.
  3. Power supply efficiency up to 94%.
  4. Current feedback, voltage feedback and temperature feedback integrate all kinds of control and protection.
  5. Guarantee the real constant current control of each chip, greatly prolong the life of the LED chip.
  6. The latest power supply technology of the power module can be added according to the customer's needs.
  7. By directly adjusting the current output to each LED chip through software, the millisecond switch with non-destructive lifetime and non-polar dimming can be achieved (the accuracy is up to 1%).

Power Supply System

## Remote monitoring function

In order to ensure the stability of global IUV customers' equipment operation, timely troubleshooting, remote OTA software upgrade and other future digital management needs, IUV has independently developed a set of perfect remote equipment management system.

This system enables IUV devices around the world to connect to the cloud server through network cables, WIFI, 5G and other Internet access.

This system can help customers quickly diagnose and solve system failures, ensure efficient production of customers. On the other hand, provide real-time data for digital management of customers' factories.

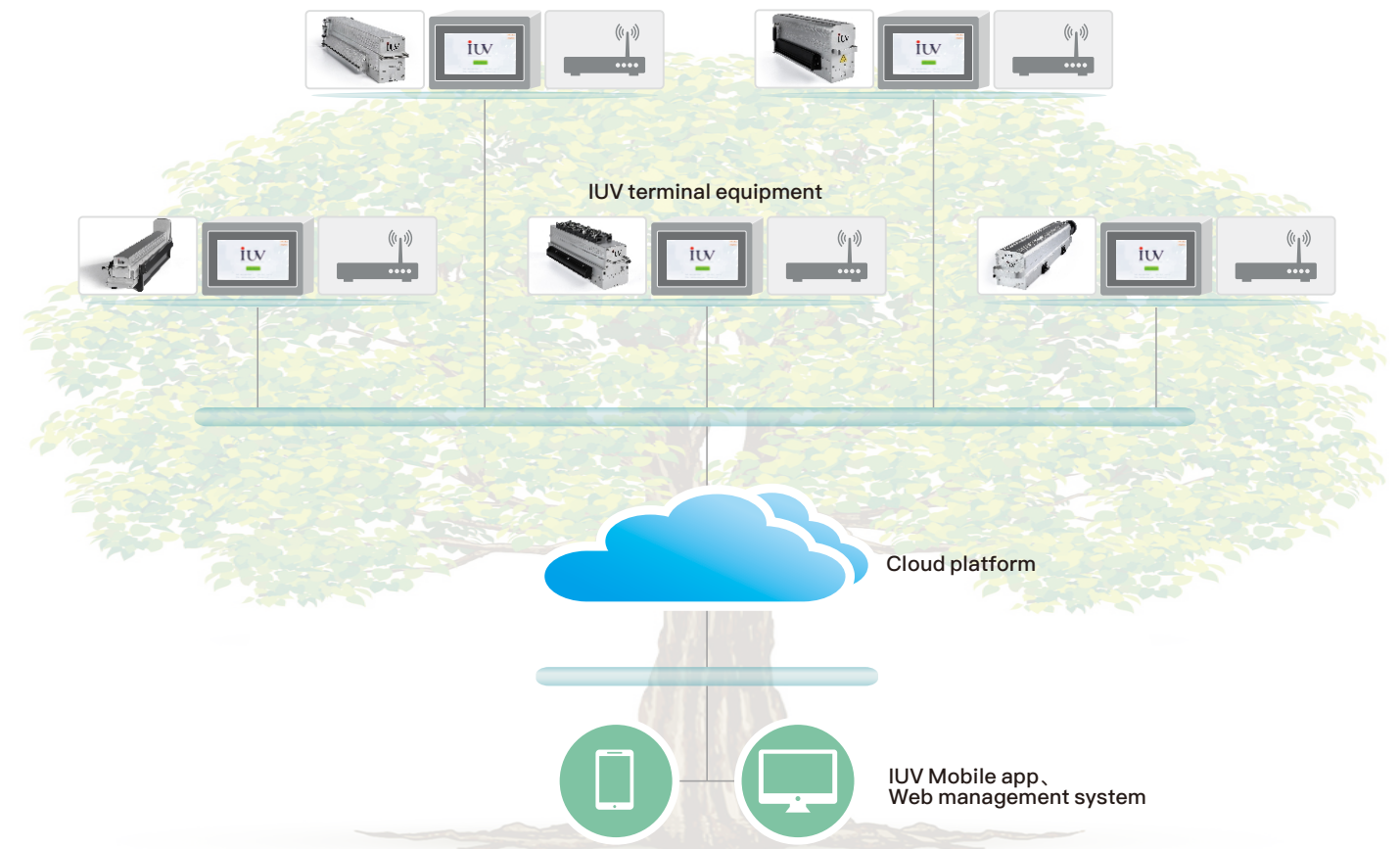



## LED intelligent detection section lighting function

The IUW's LED curing system detects the width and position of the printed material in real time, and the LED UV luminous area automatically follows the material changes.

When the width of the printing material changes from 360mm to 44mm, the LED luminous width will automatically adjust to 144mm, and the luminous area position will automatically follow the material position (the position of the material is bright, the position of the material is automatically off), this function can maximize the power saving, reduce the temperature of the material and improve the life of the LED chip.

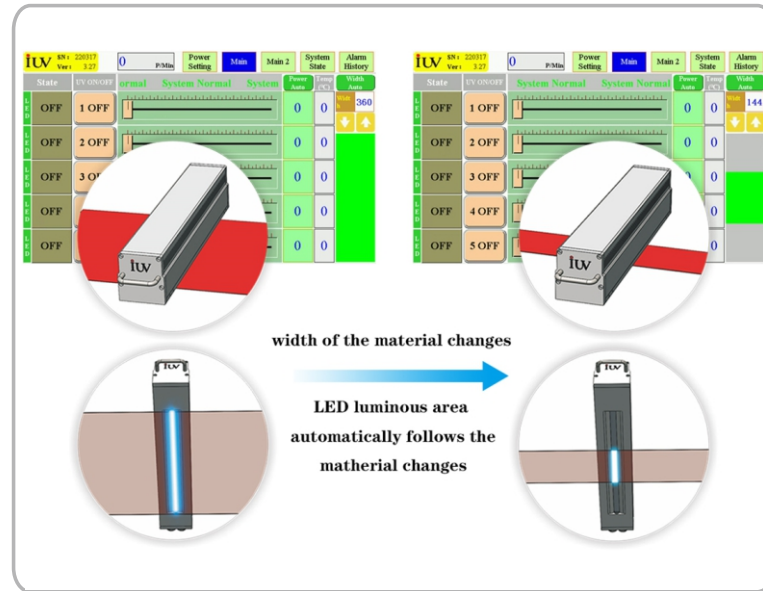

## Product introduction

### Touch Screen

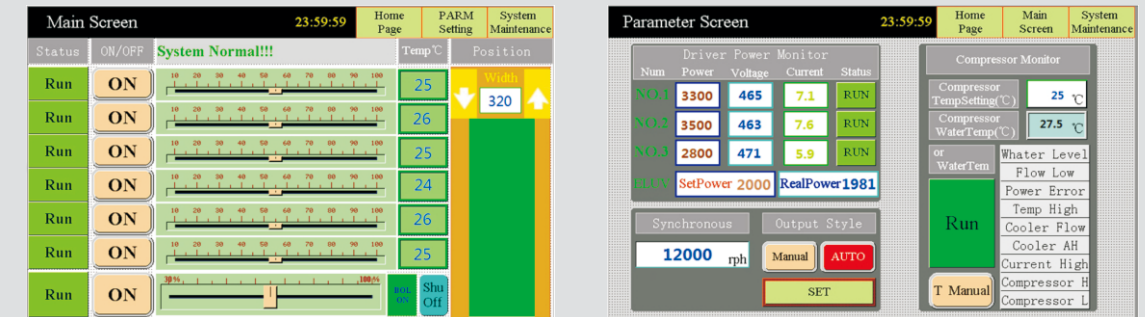

Convenient operation, flexible parameter setting and clear status display.

## Intelligent mercury cassette

IUV products are equipped with self-developed intelligent mercury cassette with perfect structure and multi-point automatic temperature detection and feedback to ensure the uniform luminescence, safe and reliable operation of mercury lamp.

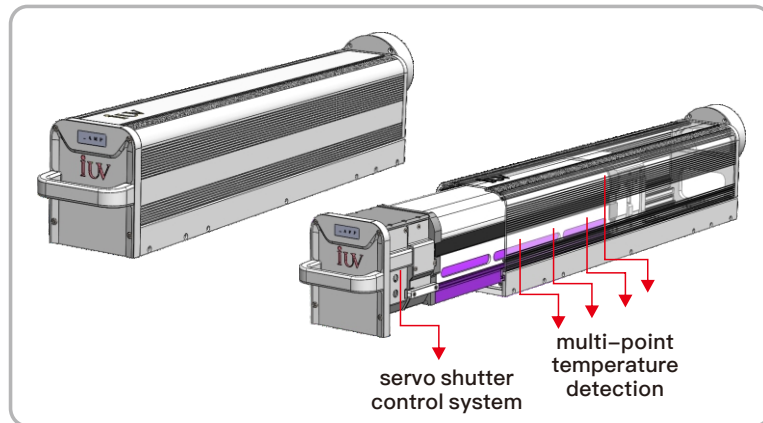

Independent developed servo shutter control system, which can intelligently control the shutter opening and closing angle and speed to ensure the full solidification and safety of solidified materials.

### Suitable For Flexographic Printing Machine



BOBST NILPETER OMET GALLUS

1. Concentrated energy and sufficient curing performance.
2. Mercury lamp box and LED box intelligently interchange.
3. Automatic detection of width and partitioned lighting.
4. Energy saving, environmental protection and stable working.

Suitable For Intermittent Label Offset Printing Machine

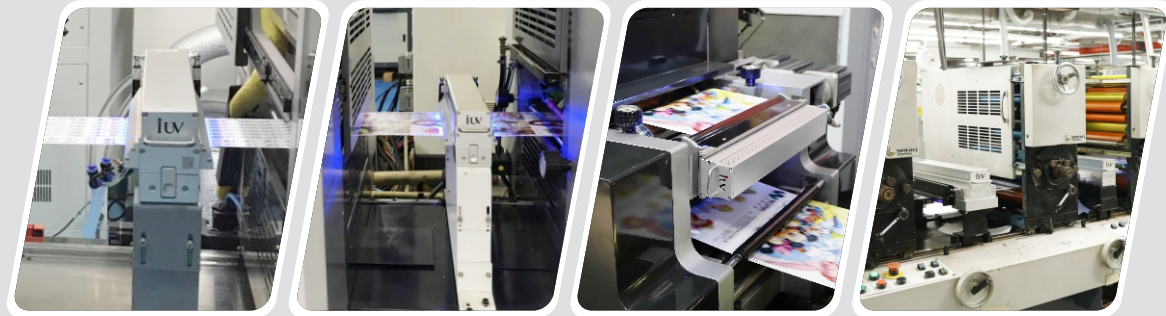

WEIGANG

HUADA

WANJIE

SANKI

1. Intelligent online, remote control.
2. Automatic detection of width and partitioned lighting.
3. Energy saving, environmental protection and stable performance.

Suitable For Wide Format Offset Printing Machine



KOMORI

RYOBI

HEIDELBERG

1. Concentrated energy and sufficient curing.
2. Simple wiring and convenient disassembly.
3. Energy saving, environmental protection and stable performance.

Suitable For Digital Printing Machine



1. Whole UV solution for pre-curing and complete curing.
2. Uniform curing and stable performance.
3. Automatic detection of width and partitioned lighting.

LED energy saving calculation (Reference)

Comparison of power consumption of LED UV and mercury UV

| Outline                                 | Web (435mm)                                     | Mercury UV (10kw)                    | LED UV (water-cooled)            |                                   |
|---|---|--------------------------------------|----------------------------------|-----------------------------------|
| Specification                           | Number of mounted lamp                          | UV lamp (8 units)                    | UV-LED (8 units)                 | UV-LED(with width sensor)(8units) |
|   | Paper width (mm)                                | 450                                  | 435                              | 250                               |
|   | Ultraviolet energy density (W/cm2)              | 1                                    | 20                               | 20                                |
|   | Power efficiency                                | 0.96                                 | 0.96                             | 0.96                              |
|   | Power consumption of lamp(operating) (KW/units) | 10                                   | 3.8                              | (250/435)*3.8=2.2                 |
|   | Total power consumption(operating) (KW)         | $10 \div 0.96 \times 8 = 83.33$      | $3.8 \div 0.96 \times 8 = 31.67$ | $2.2 \div 0.96 \times 8 = 18.33$  |
|   | Power consumption of lamp(standby) (KW)         | $10 * 0.25 = 2.5$ ( Rated power 25%) | 0                                | 0                                 |
| Total power consumption(standby) (KW)   | $2.5 \div 0.96 \times 8 = 20.83$                | 0                                    | 0                                |                                   |
| Condition                               | Operating hours in factory (H/day)              |                                      | 10                               |                                   |
|   | Operation ratio (%)                             |                                      | 70%                              |                                   |
|   | Number of operating days(22days/months):        |                                      | 264                              |                                   |
|   | Operating time(H)                               |                                      | $2640 \times 70\% = 1848$        |                                   |
|   | Standby time (H)                                |                                      | $2640 \times 30\% = 792$         |                                   |
| Total time of operating and standby (H) |   | $264 \times 10 = 2640$               |                                  |                                   |
| UV Unit Annual Power Consumption        | During operation (KWH)                          | $83.33 \times 1848 = 153993.84$      | $31.67 \times 1848 = 58526.16$   | $18.33 \times 1848 = 33873.84$    |
|   | During standby (KWH)                            | $20.83 \times 792 = 16497.36$        | 0                                | 0                                 |
|   | Operation+standby (KWH)                         | $153993.84 + 16497.36 = 170491.2$    | $58526.16 + 0 = 58526.16$        | $33873.84 + 0 = 33873.84$         |
|   | Electric charge (EUR/KWH)                       |                                      | 0.15EUR                          |                                   |
|   | Annual electricity expense (EUR)                | $170491.2 * 0.15 = 25573.68$ EUR     | $58526.16 * 0.15 = 8778.92$ EUR  | $33873.84 * 0.15 = 5081.08$ EUR   |
| Reduction                               | Annual cost reduction(EUR/year)                 |                                      | $25573.68 - 8778.92 = 16794.76$  | $25573.68 - 5081.08 = 20492.6$    |
|   | Reduction ratio                                 |                                      | $16794.76 / 25573.68 = 65.67\%$  | $20492.6 / 25573.68 = 80.13\%$    |